

SPRAYEZ-3000H HYDRAULIC PROPORTIONER USER MANUAL

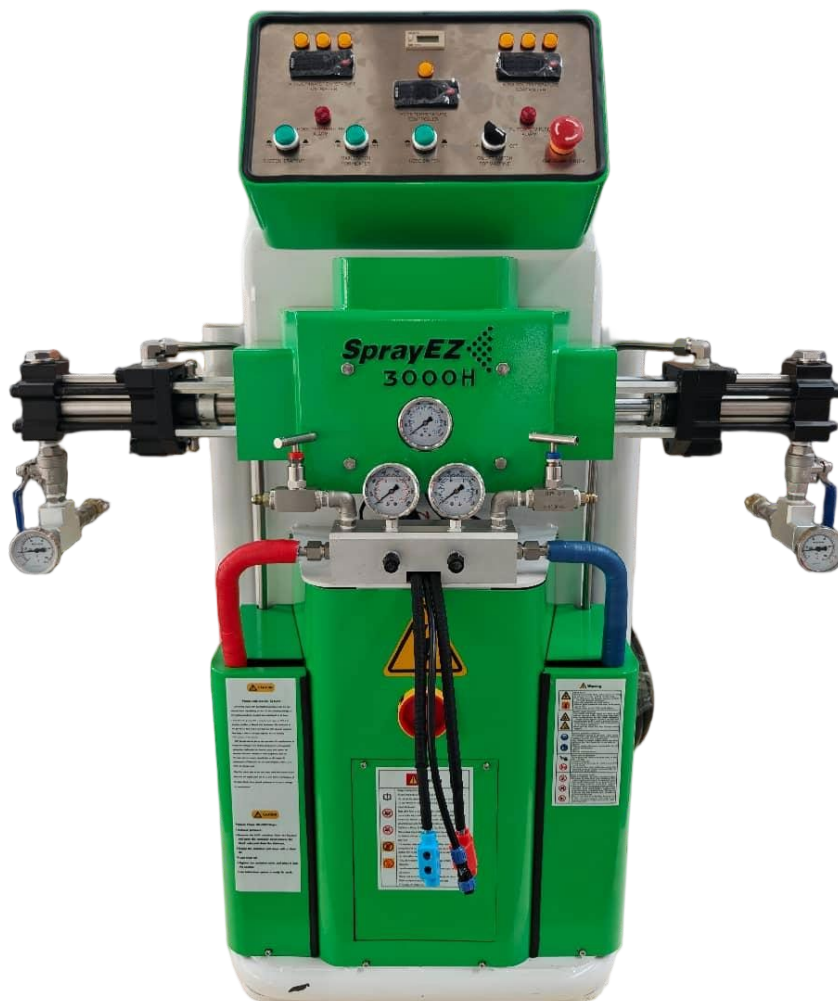

Important Safety Instructions

Read all warnings and instructions in this manual. Save these instructions.

Standard Technical Parameters,

Model	SprayEZ - 3000H Hydraulic Spray Machine
The ratio of raw material	1:1
Max working pressure	2100psi
Max fluid temperature	194°F
Max output	30lbs/min
Max heated hose length	300ft
Heated hose transformer power	3500W
Heater power	4500W×2
Drive model	Hydraulic
Whole power	17KW
Voltage	Three-phase 240V 60Hz

READ ME FRIST, IT IS VERY IMPORTANT:





- Never try to exchange ISO and POLY transfer pumps and hoses;
- Add TSL into the TSL cup before use, can not run the machine without TSL;
- After one day's work, take apart the gun blocks and mixing chamber, clean them and put them into the gun cleaning liquid;
- **CIRCULATE A-SIDE (ISO) WEEKLY;**
- Any questions, please contact us. **877.772.9629**











Contents

1. Warnings	4
2. Important Two-Component Material Information.....	8
3. Flow Charts of Raw Material	10
4. System Installation	11
5. System Operation	16
6. Hydraulic System Maintenance.....	22
7. Check for Fluid Flow System and Equipment Problems.....	23
8. Drawings.....	25

1. Warnings

The following warnings are for setup, use, grounding, maintenance, and repair of this equipment. The exclamation point symbol alerts you to a general warning and the hazard symbol refers to procedure-specific risk. Refer back to these warnings. Additional, product-specific warnings may be found throughout the body of this manual where applicable.

 WARNING	
	<p>ELECTRIC SHOCK HAZARD</p> <p><i>This equipment must be ground. Improper grounding, setup, or usage of the system can cause electric shock.</i></p> <ul style="list-style-type: none"> • <i>Turn off and disconnect power at main switch before disconnecting any cables and before servicing equipment.</i> • <i>Connect only to grounded power source.</i> • <i>All electrical wiring must be done by a qualified electrician and comply with all local codes and regulations.</i>
	<p>TOXIC FLUID OR FUMES HAZARD</p> <p><i>Toxic fluids or fumes can cause serious injury or death if splashed in the eyes or on skin, inhaled, or swallowed.</i></p> <ul style="list-style-type: none"> • <i>Read MSDS to know the specific hazards of the fluids you are using.</i> • <i>Store hazardous fluid in approved containers, and dispose of it according to applicable guidelines.</i> • <i>Always wear chemically impermeable gloves when spraying, dispensing, or cleaning equipment.</i>
	<p>PERSONAL PROTECTIVE EQUIPMENT</p> <p><i>You must wear appropriate protective equipment when operating, servicing, or when in the operating area of the equipment to help protect you from serious injury, including eye injury, inhalation of toxic fumes, burns, and hearing loss. This equipment includes but not limited to:</i></p> <ul style="list-style-type: none"> • <i>Protective eyewear</i> • <i>Clothing and respirator as recommended by the fluid and solvent manufacturer</i> • <i>Gloves</i> • <i>Hearing protection</i>

 WARNING	
  	<p>SKIN INJECTION HAZARD</p> <p><i>High-pressure fluid from gun, hose leak, or ruptured components will pierce skin. This may look like just a cut, but it is a serious injury that can result in amputation. Get immediate surgical treatment.</i></p> <ul style="list-style-type: none"> • Engage raw material valve lock when not spray. • Do not point gun at anyone or at any part of the body. • Do not put your hand over the spray tip. • Do not stop or deflect leaks with your hand, body, glove, or rag. • Turn off the machine when you stop spraying and before cleaning, checking, or servicing equipment. • Tighten all fluid connections before operating the equipment. • Check hoses and couplings daily. Replace worn or damaged parts immediately.
   	<p>FIRE AND EXPLOSION HAZARD</p> <p><i>Flammable fumes, such as solvent and paint fumes, in work area can ignite or explode. To help prevent fire and explosion:</i></p> <ul style="list-style-type: none"> • Use equipment in well ventilated only. • Eliminate all ignition sources; such as pilot lights, cigarettes; plastic drop cloths, and portable electric lamps. • Keep work area free of debris, including solvent, rags and gasoline. • Do not plug or unplug power cords, or turn power or light switch on or off when flammable fume are present. • Ground all equipment in the work area. • Hold gun firmly to side of grounded pail when triggering into pail. • If there is a static sparking or you feel a shock, stop operation immediately. Do not use equipment until you identify and correct the problem. • Keep a working fire extinguisher in the work area.
  	<p>THERMAL EXPANSION HAZARD</p> <p><i>Fluid subjected to heat in confined spaces, including hoses, can create a rapid rise in pressure due to the thermal expansion. Over-pressurization can result in equipment rupture and serious injury.</i></p> <ul style="list-style-type: none"> • Open a valve relieves the fluid expansion during heating. • Replace hoses proactively at regular intervals based on your operation conditions.

**WARNING****PRESSURIZED ALUMINUM PARTS HAZARD**

Use of fluids that incompatible with aluminum in pressurized equipment can cause serious chemical reaction and equipment rupture. Failure to follow this warning can result in death, serious injury, or property damage.

- *Do not use 1,1,1-trichloroethane, methylene chloride, other halogenated hydrocarbon solvents for fluids containing such solvents.*
- *Many other fluids may contain chemicals that can react with aluminum. Contact your material supplier for compatibility.*

**EQUIPMENT MISUSE HAZARD**

Misuse can cause death or serious injury.

- *This equipment is for **Professional** use only.*
- *Do not leave the work area while the equipment is energized or under pressure. Turn off all equipment when the equipment is not in use.*
- *Do not operate the unit when fatigued or under the influence of drugs or alcohol.*
- *Do not exceed the maximum working pressure or temperature rating of the lowest rated system component. See **Technical Data** in all equipment manual.*
- *Use fluids and solvents that are compatible with equipment wetted parts. See **Technical Data** in all equipment manuals. Read fluid and solvent manufacturer's warnings. For complete information about your material, request MSDS forms from distributor or retailer.*
- *Check equipment daily. Repair or replace worn or damaged parts immediately with genuine manufacturer's replacement parts only.*
- *Do not alter or modify equipment.*
- *Use equipment only for its intended purpose. Call your distributor for information.*
- *Route hoses and cables away from traffic areas, sharp edges, moving parts, and hot surfaces.*
- *Do not kink or over bend hoses or use hoses to pull equipment.*
- *Keep children and animals away from work area.*
- *Comply with all applicable safety regulations.*

**WARNING****MOVING PARTS HAZARD**





Moving parts can pinch or amputate fingers and other body parts.



- *Keep clear of moving parts.*
- *Do not operate equipment with protective guards or covers removed.*
- *Pressurized equipment can start without warning. Before checking, moving, or servicing equipment, follow the Pressure Relief Procedure in this manual. Disconnect power or air supply.*



**BURN HAZARD**

Equipment surfaces and fluid that's heated can become very hot during operation. To avoid severe burns, do not touch hot fluid or equipment. Wait until equipment/fluid has cooled completely.

2. Important Two-Component Material Information

Isocyanate Conditions	
   	<ul style="list-style-type: none"> • <i>Spraying or dispensing materials containing isocyanates creates potentially harmful mists, vapors, and atomized particulates.</i> • <i>Read material manufacturer’s warnings and material MSDS to know specific hazards and precautions related to isocyanates.</i> • <i>Prevent inhalation of isocyanate mists, vapors, and atomized particulates by providing sufficient ventilation in the work area. If sufficient ventilation is not available, a supplied-air respirator is required for everyone in the work area.</i> • <i>To prevent contact with isocyanates, appropriate personal protective equipment, including chemically impermeable gloves, boots, aprons, and goggles, is also required for everyone in the work area.</i>

Material Self-ignition	
 	<p><i>Some materials may become self-igniting if applied too thickly. Read material manufacturer’s warnings and material MSDS.</i></p>

Keep Components A and B Separate	
 	<p><i>Cross-contamination can result in cured material in fluid lines which could cause serious injury or damage equipment. To prevent cross-contamination of the equipment’s wetted parts, never interchange component A (isocyanate) and component B (resin) parts.</i></p>

Moisture Sensitivity of Isocyanates

Isocyanates (ISO) are catalysts used in two component foam and polyurethane coatings. ISO will react with moisture (such as humidity) to form small, hard, abrasive crystals, which become suspended in the fluid. Eventually a film will form on the surface and the ISO will begin to gel, increasing in viscosity. If used, this partially cured ISO will reduce performance and the life of all wetted parts.

The amount of film formation and rate of crystallization varies depending on the blend of ISO, the humidity, and the temperature.

To prevent exposing ISO to moisture:

- Always use a sealed container with a desiccant dryer in the vent, or a nitrogen atmosphere. Never store ISO in an open container.
- Keep the ISO lube pump reservoir (if installed) filled with TSL. The lubricant creates a barrier between the ISO and the atmosphere.
- Use moisture-proof hoses specifically designed for ISO, such as those supplied with your system.
- Never use reclaimed solvents, which may contain moisture. Always keep solvent containers loosed when not in use.
- Never use solvent on one side if it has been contaminated from the other side.
- Always lubricate threaded parts with ISO pump oil or grease when reassembling.

Changing Materials

- When changing materials, flush the equipment multiple times to ensure it is thoroughly clean.
- Always clean the fluid inlet strainers after flushing.
- Check with your material manufacturer for chemical compatibility.

3. Flow Charts of Raw Material

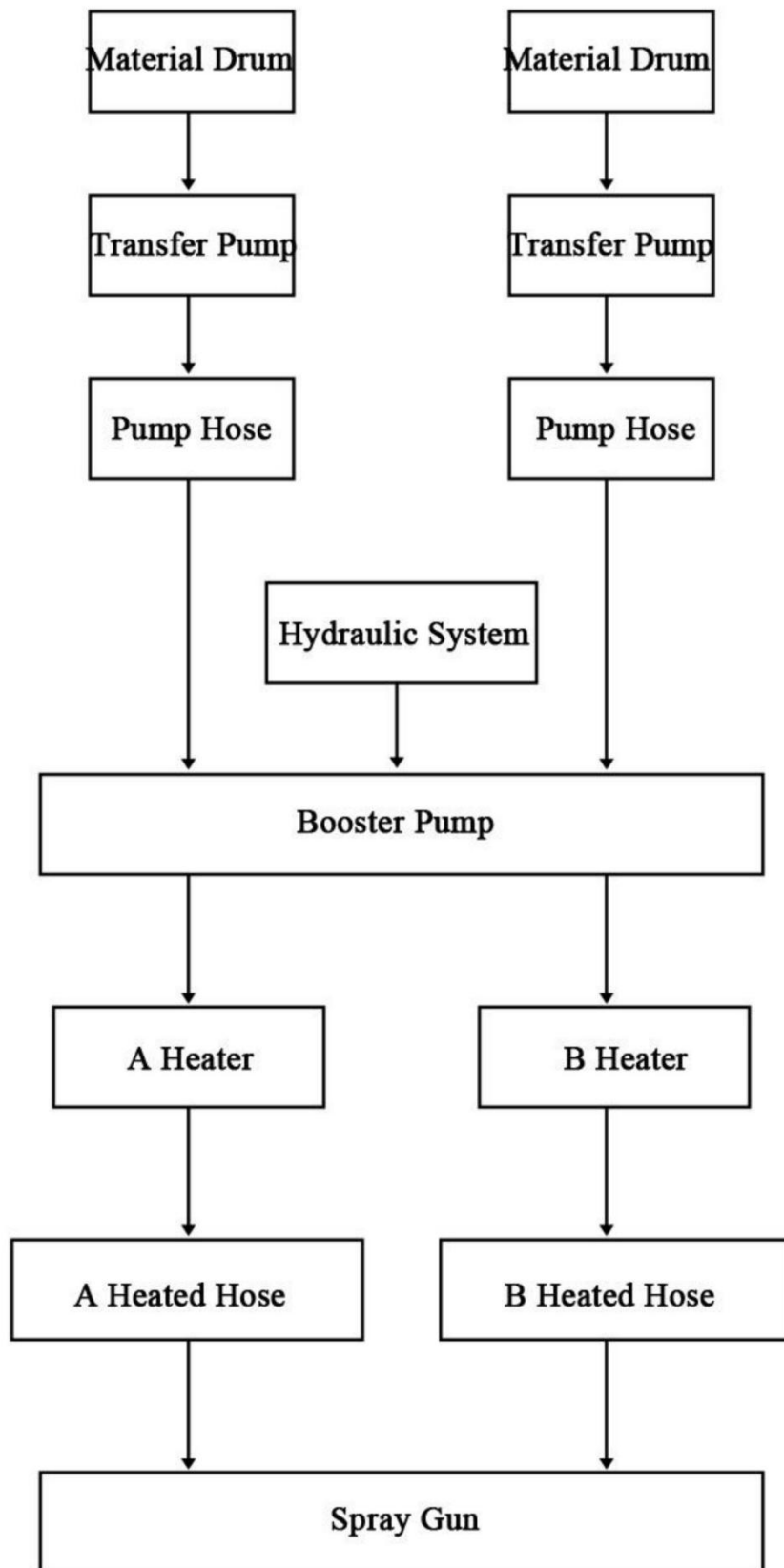

4. System Installation

4.1 Installation of raw material pipe system:

Lead the POLY and ISO from material drum to the pump entrance of the mainframe; connect hoses of chemical material and air to spray gun respectively as the following steps.

1. Installation of material feeding system:

1.1 Open the drum put in the material transfer pump

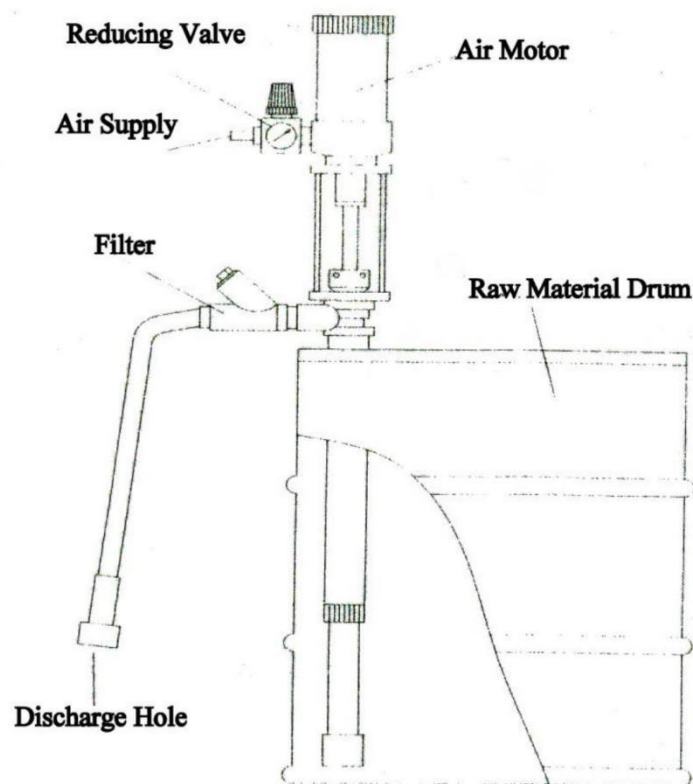

Figure (2)

1.2 Connect the pump hose to discharge hole of transfer pump and the booster pump entrance of the mainframe respectively. As figure (3)

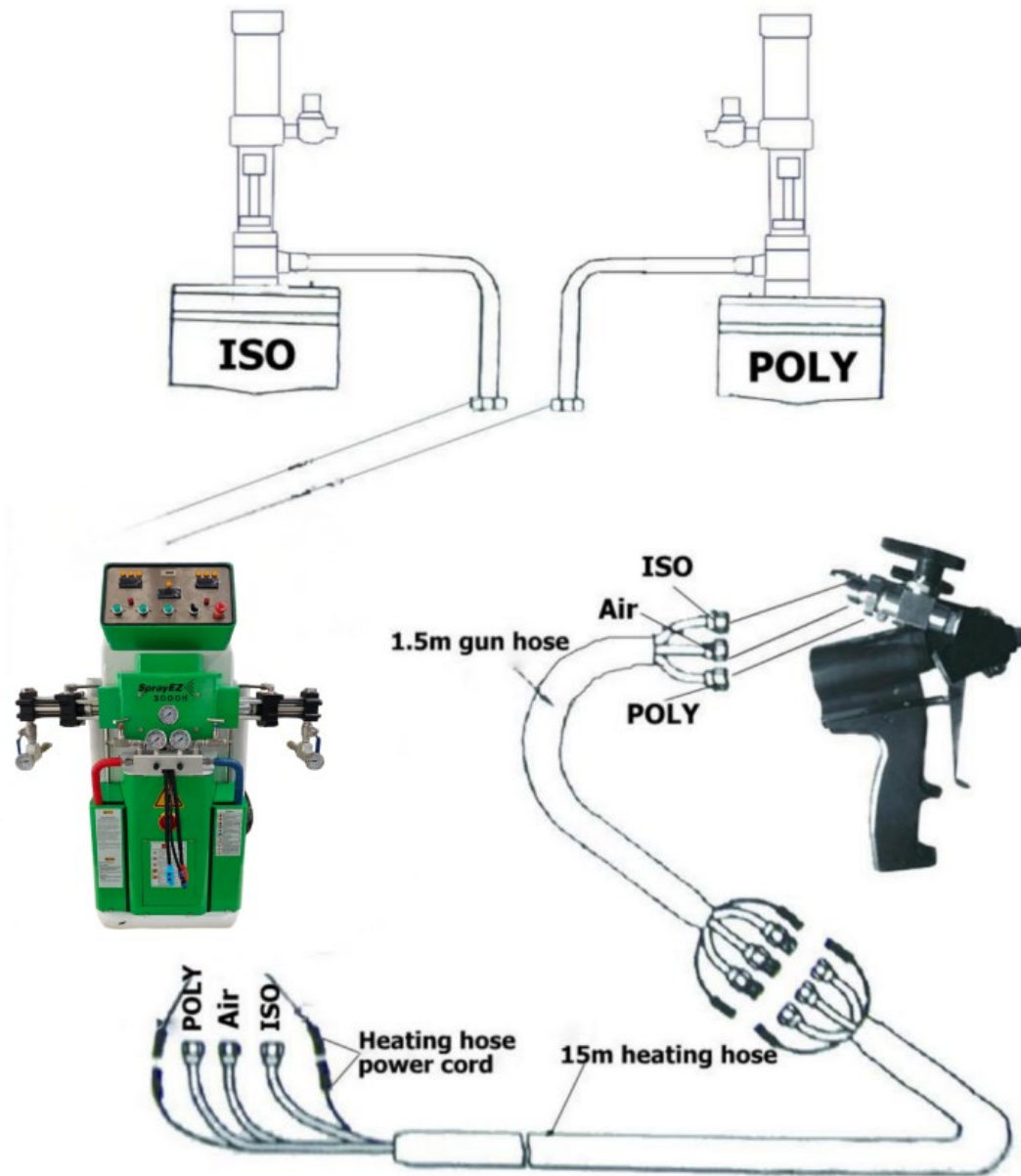

Figure (3)

2. Installation of heated hose

Connect the hose to the mainframe and spray gun respectively.

Connect the power cord of heating hose, to the transformer output wire that gives the heated hose 40 amps max power

See as figure (4).

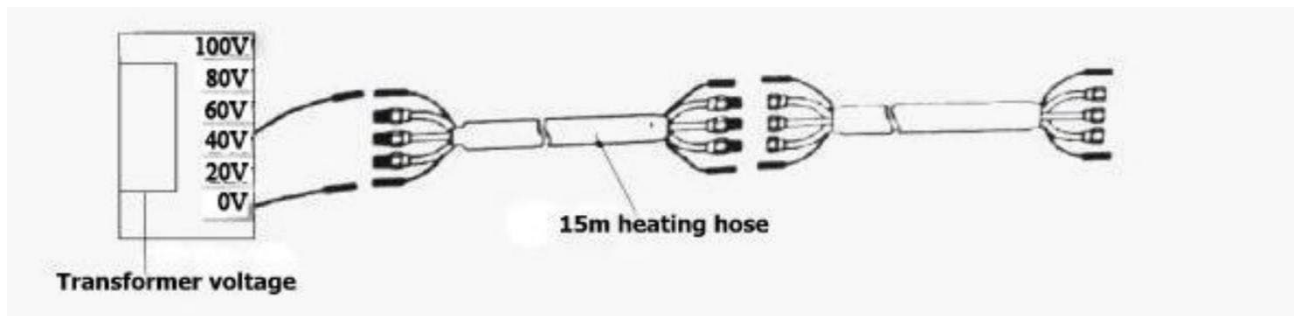

Figure (4)

4.2. The connection and requirement of power source

Connect the power line from the mainframe to **three-phase 240V 60Hz** power which is equipped with a breaker. The yellow/green line is a protective grounding wire.

WARNING

- *Installing this equipment requires access to parts which may cause electric shock or other serious injury if work is not performed properly. Be sure your installation complies with all National, State and Local safety and fire codes.*
- *The two wires of the instrument panel are charged when the main power turn on. So turn off the main power when maintaining the equipment*

4.3 Control panel: as Figure (5)



Figure (5)

1. Emergency Stop

Press the stop switch in an emergency situation, then the machine will stop working. But the equipment system is still electrified. Be sure to cut off the main power when you want to maintain the equipment. After finishing maintenance, turn the knob clockwise then it will reset when the equipment recovers to working state.

2. System Startup

This switch controls the hydraulic system, pressing this button, the electrical motor will start running, if not, swap any two of the power cords connection order.

3. Main Switch for Heater

The main power switch controls the heater power. Press this button, A, B and heated hose controller temperature will display.

4. Hose Switch

The hose switch controls the heated hose transformer power. Press this button, heated hose controller temperature will display.

5. Temperature Controller

A Isoyanate temperature controller for A side heater temperature display and set, B Polyol temperature controller for B side heater temperature display and set, Hose temperature controller for heated hose temperature display and set.

How to set temperature

1. Press **“MAIN SWITCH FOR HEATER”** to **“ON”** position,
2. Press **“SET”** knob on the controller three times, the LED digital Continuous flashing,
3. Press **▲** or **▽** to set the temperature,
4. Press **“SET”** one time finish the setting.

6. Counts

For recording the booster pump runs, press button on counts, the number back to “0”.

7. ON/OFF Switch for Machine

This switch controls connection between hydraulic system and booster pump. It has two positions, “WORK” and “RESET”, on “WORK” position, hydraulic system drive the booster pump working, the chemical has high pressure inside, on “RESET” position, the hydraulic system and booster pump disconnect, booster pump will stop working.

8. Hose Temperature Alarm

When this indicator light flashes, it indicates that the heated hose has exceeded the maximum temperature limit. The machine automatically stops operating at the same time.

9. Oil Temperature Alarm

When this indicator light flashes, it indicates that the hydraulic oil temperature of the hydraulic system has exceeded the limit temperature. At this point, the machine automatically stops operating.

4.4 Main Power Switch

This switch controls whole machine power.



Figure (6)

5. System Operation

5.1. The check before operation

1. There are 4/5 TSL (Throat Seal Liquid) in the oil cup of mainframe or not. The supply pipe (Coarser pipe) should in the cup 1/3 position, return pipe (Finer pipe) in the bottom of the cup. (Figure 8).

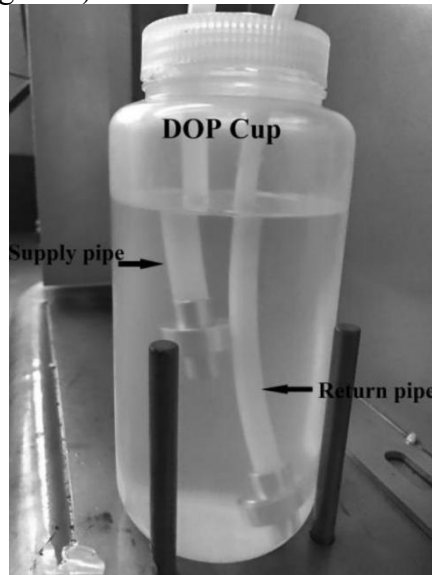

Figure (8)

2. All the connectors are tightened or not.
3. The connection of power line is correct or not. The protective grounding wire is safe and reliable or not.
4. All the switch on the control panel is in the OFF position or not.

Don't put any parts of body in the range of spray.
Don't let the gun point to someone.
Don't look into the hole of the gun mixing chamber.

Please use safety appliances like mask, gloves, goggles and protective clothing, for the objectionable constituent in the raw material.

5.2. Initial start (The first use of the new machine)

NOTICE

Proper system setup, startup, and shutdown procedures are critical to electrical equipment reliability. Failure to follow safety procedures will cause voltage fluctuations that can damage electrical equipment and void the warranty.

WARNING

Do not operate this machine without all covers and shrouds in place.

Before operate the system you must make sure all fluid flow pipes, air supply pipes and power cords are connected and correct. The operator must fully understand every

part on the control panel, steps as follows:

1. Turn on the Main Power Switch, press System Startup to “ON” position, turn ON/OFF Switch for Machine to “WORK” position, the electrical should run now, and adjust the hydraulic pressure 2Mpa-5Mpa. The system, heater and heated hose are filled by raw material. Once filled up, machine will stop working automatically.

WARNING

The direction of rotation of the electrical motor should be consistent with the direction of the arrow, otherwise it will cause no pressure in system and damage the system. See Figure 9.



Figure (9)

How to adjust the hydraulic system pressure:

- Loosen the locking nut of the pressure adjustment screw with a wrench, (Figure 10)
- Rotate the pressure adjustment screw, clockwise to increase the pressure, counterclockwise to reduce the pressure (The general working pressure is 5Mpa-7Mpa), (Figure 11)
- When the pressure adjustment is completed, lock the lock nut of the pressure adjustment screw with the wrench.

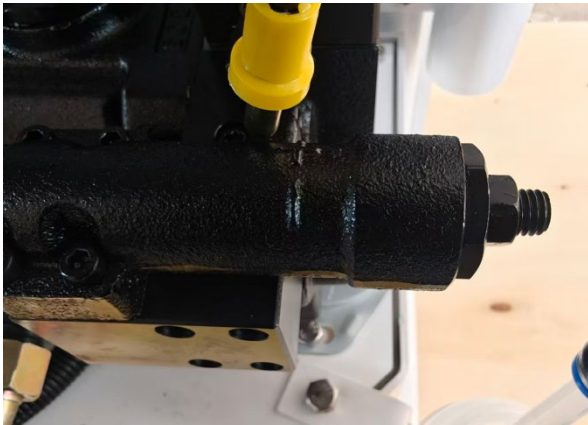

Figure (10)



Figure (11)

NOTICE

In the hydraulic system has relief valve, the relief valve set pressure is 9Mpa, the role is to limit the working pressure of the hydraulic system.

Adjust the hydraulic system pressure, should observe the hydraulic system pressure gauge, if increase system pressure, hydraulic system pressure gauge is no longer rising, then the relief valve start to work, should reduce the hydraulic system pressure until the hydraulic system pressure gauge pointer down.

Do not operate the equipment under the pressure relief or overflow condition of the relief valve.

2. Remove the two transporting blocks beside the tip of the gun.
3. Place clean containers under two transporting block respectively. At the same time, turn on the raw material valve of two transporting block slowly, let all air in the transporting pipe out, till spray material smoothly. As figure (12)

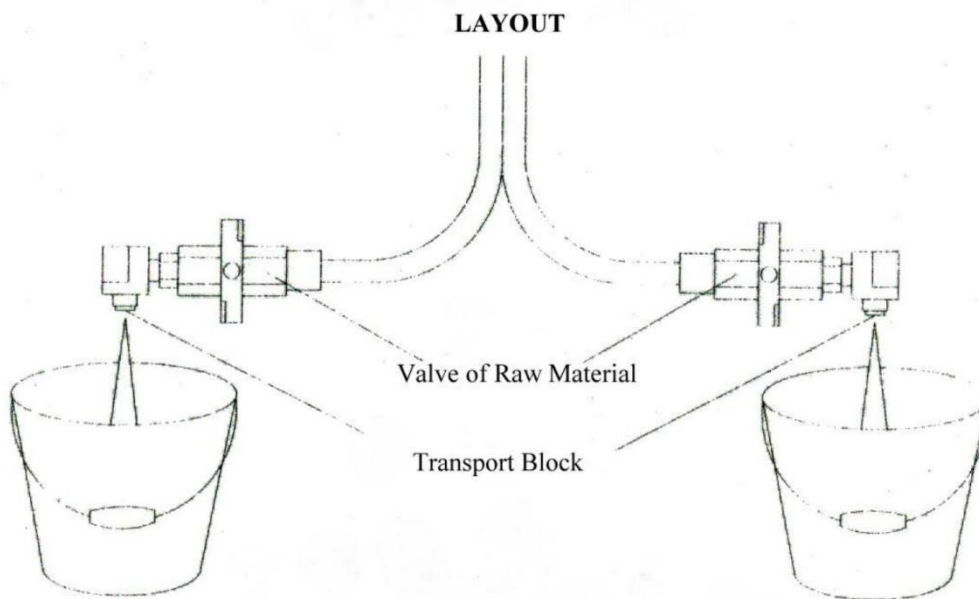

Figure (12)

4. Close raw material valve at the same time, the pressure value shown on the pressure gauge of raw material should be approximate equality. If one of them is higher, turn on the raw material valve slightly on higher side, let raw material flow out, till the two pressures are approximately equality.

5. Clean the traces of raw materials on transporting block, coated with Vaseline, install the transporting block to the gun again. Tighten the screws, let two transporting block closely contact with the gun tip, make sure no air/material leakage and the gun tip in flexible motion.

6. Straighten the transporting pipe to avoid uneven Heating and Damage internal heating wire. Set to make the heating temperature well. After temperature is up to the setting value, then improve the hydraulic system pressure to the working pressure (5Mpa-8Mpa).

WARNING

1. Before spraying, don not set the hydraulic pressure at the value of working pressure to avoid damaging pressure gauge for high pressure, and even explosion, because the raw material will expand when heated.

2. Make sure turn on/off two valves of raw material at the same time, or maybe block the spray gun.

7. Turn on the inlet switch of the gun first, then the raw material valve on the two transporting block.

8. At the moment, the whole system prepared, and it can spray as long as pull the trigger.

NOTICE

*Make sure turn off the raw material valve **at the same time** on the two transporting block when you stop working to avoid spraying due to wrong operation.*

5.3. Daily Shutdown Steps**NOTICE**

Put the reset/work switch to the reset place every time when shutdown, let the pump shaft all in the oil, avoid scratching the seal element in the pump again started.

1. Press Main Switch for Heater button, shut down the heated system,
2. Press System Startup button, shut down the hydraulic system,
3. Turn off the Main Switch of equipment, shut down the whole system,
4. Close two valves on the gun blocks,
5. Close the air supply of whole system,
6. Disconnect the power cord of whole system,
7. Clean up the site, confirm the daily shutdown steps is completed.

5.4. Long-time Shutdown Steps

This step is for long-term shutdown or storage of machine. Please follow the steps to operate: (mainly for the isocyanate)

1. Close the air supply and the Main Power Switch, take transfer pumps out from the raw material drums, use the solvent to clean the outside of transfer pumps,
2. Place transfer pumps in a container with clean solvent, ISO and POLY transfer pumps should be placed in separate containers,
3. Open the air pressure valve on transfer pump, adjust air pressure to 0.1Mpa-0.2Mpa,
4. Turn on the Main Power Switch,
5. Press the System Startup button, start hydraulic system, adjust the hydraulic system to 2Mpa-3Mpa,
6. Make sure gun valves close, take off gun valves,
7. Open gun valves, spill the equipment chemical into suitable containers until a clean solvent appears,

Above procedures use solvent cleaning system

8. Put transfer pumps into the container with TSL (Throat Seal Liquid), repeat the above steps, until clean TSL appears at outlet,

9. Follow daily shutdown steps, seal all inlet and outlet openings, put transfer pumps into container with TSL.

NOTICE

Isocyanate and air is easy to crystallize, all inlet and outlet must be strictly sealed to prevent air from entering.

6. Hydraulic System Maintenance

In the hydraulic system, the hydraulic oil purity and oil content are very important. If the hydraulic oil include impurities will cause the whole system not work. So must ensure the system hydraulic oil purity. System oil shortage can easily lead to excessive temperature rise too fast, leaving the viscosity of hydraulic oil lower, resulting in system pressure is too low and affect the work of the system. Usually the amount of hydraulic oil should be 2/3 level. Figure (13).



Figure (13)

How to choose hydraulic oil?

According to different regions of the ambient temperature difference to choose a different hydraulic oil to ensure the normal operation of the system.

Generally use more than 68 # hydraulic oil.

For temperatures below 41 degrees fahrenheit, should use 32 # or 48 # hydraulic oil,

How often to replace the hydraulic oil?

The hydraulic system should be replaced hydraulic oil every 2 years.

How to adjust the relief valve?

Relief valve has been set before leaving the factory, generally do not need to adjust.

7. Check for Fluid Flow System and Equipment Problems

You must know the following questions as a qualified operator:

1. What the normal raw material looks like?
2. How to work of the equipment?
3. What will be when machine in normal work?
4. How to move the raw material in the machine?

7.1. Checking when the hydraulic pressure gauges wrong display:

Checking must from step one, then one by one. Determine by the pressure displayed on the raw material pressure gauge.

1. Confirm which material is shortage and miss.

First, observe the material color spraying from the gun and the foam state, stop spraying to check when with problems. If the raw material pressure is lower, it means underfeeding of material transfer pump system. Check if the material feeding system blocking or no material in drum.

2. If underfeeding, check and repair from the farthest end to the mainframe, and begin from the most basic and easily be found aspect.

3. If the raw material pressure too low check as follows:

(1) If there are raw materials in the drum?

(2) What's the temperature of raw material?

A. High temperature will cause expand in advance of the foaming agent in the poly drum.

B. Low temperature of the drum bottom will cause raw material viscosity increases then block the material transfer pump or raw material flow impeded and can't enter the system.

(3) Transfer pump does not work?

A. Running or not?

B. Turn on the air supply?

C. Air supply pressure in a proper value?

D. There is dirt on the shaft of feeding material pump? (If yes, mean it not be wiped oil for protection in advance, or the oil cup not tighten, cause to material overflow)

E. Check the filter of material transfer pump.

F. Confirm the material transfer pump body after sure there are no problems in other parts. Specially note the B, in 2 point of step3.

(4) Filter: install a filter on the Material transfer pump discharge? Or it blocks?

4. Check as follows if the raw material pressure too high

(1) If the filtering net of the transporting block on gun blocks.

(2) If there are curing and crystalline materials in the hose from raw material pressure gauge to the gun, cause raw material flow impeded.

7.2. Maintenance of mainframe

The device commutation system is electrically controlled commutation. The commutation system is composed of hydraulic electromagnetic reversing valve, LJI, LJII (commutation metal sensing switch) and internal DC commutation circuit.

The working principle is as follows:

When the device is powered on, turn on the Main Power Switch, press the “SYSTEMSTARTUP”, turn “ON/OFF SWITCH FOR MACHINE” to “ON” position, booster pump according to the pressure in the system, do the level of reciprocating motion. The reversing metal sensing switch is mounted on the booster pump connection block, with the booster pump to do horizontal reciprocating motion. Booster pump movement stroke and reversal point, determined by the location of LJI and LJII.

If device does not work, it can be checked from the following aspects:

- (1) The device is powered on or not?
- (2) The “SYSTEM STARTUP” on “ON” position or not?
- (3) The “ON/OFF SWITCH FOR MACHINE” on “ON” position or not?
- (4) Hydraulic system pressure is too high, so that relief valve working? (The hydraulic system pressure should no more than 7Mpa.)
- (5) Hydraulic station oil temperature is too high? Overheating caused by the oil temperature protection relay action cut off the control power supply. When the oil temperature has dropped to 122° Fahrenheit , the control power will automatically turn on.
- (6) LJI, LJII and metal sensing switch space should be between 2mm-4mm.
- (7) The proximity switch is damaged by external force?
- (8) The impurities in the hydraulic oil solenoid valve spool stuck, can not change the action?
- (9) Booster pump shaft seal leaking or not? If it is leaking the isocyanate will crystallize and the booster pump will be locked.

8. Circuit diagram and decomposed diagram of the booster pump

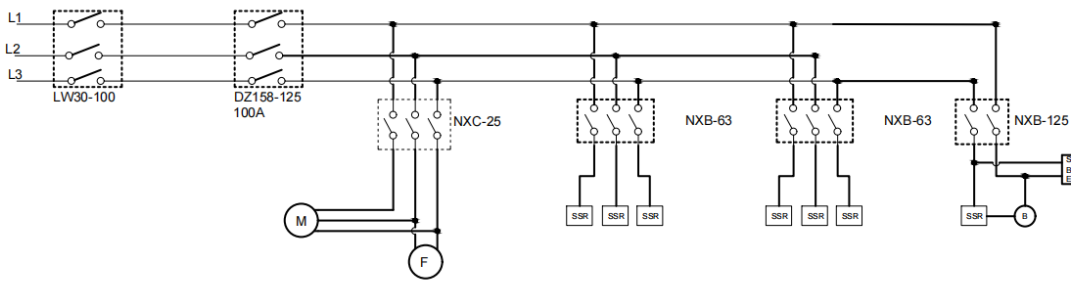

System startup contactor wiring diagram

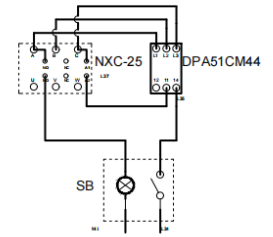

Secondary wiring diagram

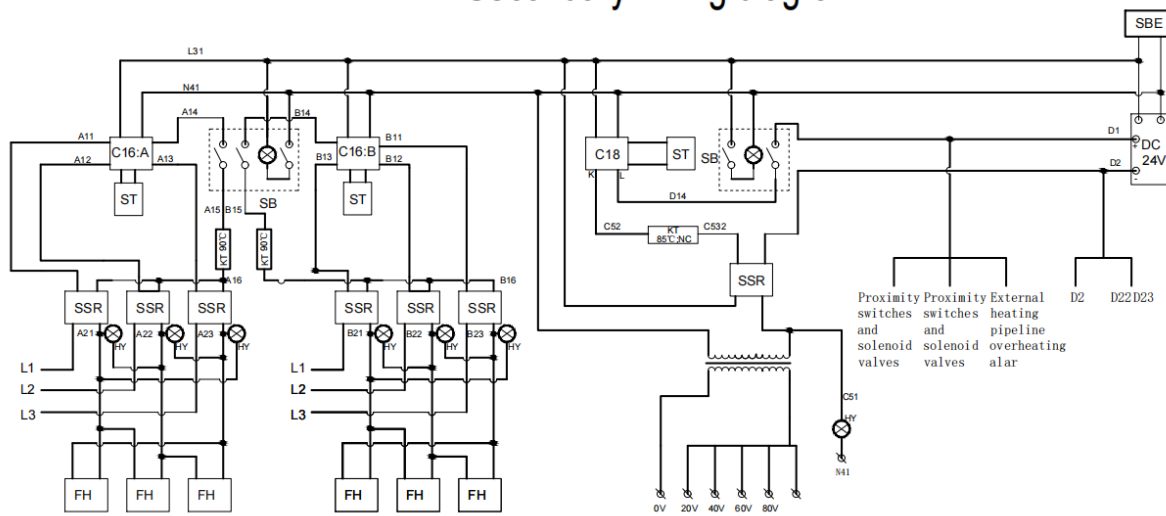

Wiring diagram for external tube heating

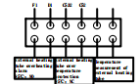

Alarm wiring diagram



Relay wiring diagram

