

SPRAYEZ-3000 POLYURETHANE SPRAY MACHINE USER MANUAL



Important Safety Instructions

Read all warnings and instructions in this manual. Save these instructions.

Standard Technical Parameters,

READ ME FRIST, IT IS VERY IMPORTANT:

- Never mix ISO and POLY pumps/hoses
- Add Throat seal liquid (TSL) into the TSL cup before use, if there is no TSL, you can not use the machine. Check TSL before each use of the machine;
- **Circulate the A side fluid weekly if equipment is not used.**
- Any questions, please contact us. 877.772.9629

Contents

1. Warnings	4
2. Important Two-Component Material Information	8
3. Flow Charts of Raw Material	10
4. System Installation	11
5. System Operation	18
6. Check for Fluid Flow System and Equipment Problems	22
7. Drawings	24

877.772.9629

SprayEZ

Spray Equipment
and Coatings

SprayEZ.com

SPRAYEZ - 3000 TDS SHEET







Model	SprayEZ-3000
Max working pressure	2000 PSI
Max hose length	250 feet
Max fluid temperature	194°F
Max output	30 Lbs per minute
Heater power	12000W (6000W X 2)
Heating hose power	4,000W
Voltage	1-ph 220V 60HZ











SprayEZ

Spray Equipment
and Coatings

1. Warnings

The following warnings are for setup, use, grounding, maintenance, and repair of this equipment. The exclamation point symbol alerts you to a general warning and the hazard symbol refers to procedure-specific risk. Refer back to these warnings. Additionally, product-specific warnings may be found throughout the body of this manual where applicable.

 WARNING	
	<p>ELECTRIC SHOCK HAZARD</p> <p><i>This equipment must be grounded. Improper grounding, setup, or usage of the system can cause electric shock.</i></p> <ul style="list-style-type: none"> • <i>Turn off and disconnect power at main switch before disconnecting any cables and before servicing equipment.</i> • <i>Connect only to grounded power source.</i> • <i>All electrical wiring must be done by a qualified electrician and comply with all local codes and regulations.</i>
	<p>TOXIC FLUID OR FUMES HAZARD</p> <p><i>Toxic fluids or fumes can cause serious injury or death if splashed in the eyes or on skin, inhaled, or swallowed.</i></p> <ul style="list-style-type: none"> • <i>Read MSDS to know the specific hazards of the fluids you are using.</i> • <i>Store hazardous fluid in approved containers, and dispose of it according to applicable guidelines.</i> • <i>Always wear chemically impermeable gloves when spraying, dispensing, or cleaning equipment.</i>
	<p>PERSONAL PROTECTIVE EQUIPMENT</p> <p><i>You must wear appropriate protective equipment when operating, servicing, or when in the operating area of the equipment to help protect you from serious injury, including eye injury, inhalation of toxic fumes, burns, and hearing loss. This equipment includes but not limited to:</i></p> <ul style="list-style-type: none"> • <i>Protective eyewear</i> • <i>Clothing and respirator as recommended by the fluid and solvent manufacturer</i> • <i>Gloves</i> • <i>Hearing protection</i>

 WARNING	
  	<p>SKIN INJECTION HAZARD</p> <p><i>High-pressure fluid from gun, hose leak, or ruptured components will pierce skin. This may look like just a cut, but it is a serious injury that can result in amputation. Get immediate treatment.</i></p> <ul style="list-style-type: none"> • Engage raw material valve lock when not spraying. • Do not point gun at anyone or at any part of the body. • Do not put your hand over the spray tip. • Do not stop or deflect leaks with your hand, body, glove, or rag. • Turn off the machine when you stop spraying and before cleaning, checking, or servicing equipment. • Tighten all fluid connections before operating the equipment. • Check hoses and couplings daily. Replace worn or damaged parts immediately.
   	<p>FIRE AND EXPLOSION HAZARD</p> <p><i>Flammable fumes, such as solvent and paint fumes, in work area can ignite or explode. To help prevent fire and explosion:</i></p> <ul style="list-style-type: none"> • Use equipment in well ventilated only. • Eliminate all ignition sources; such as pilot lights, cigarettes; plastic drop cloths, and portable electric lamps. • Keep work area free of debris, including solvent, rags and gasoline. • Do not plug or unplug power cords, or turn power or light switch on or off when flammable fume are present. • Ground all equipment in the work area. • Hold gun firmly to side of grounded pail when triggering into pail. • If there is a static sparking or you feel a shock, stop operation immediately. Do not use equipment until you identify and correct the problem. • Keep a working fire extinguisher in the work area.
  	<p>THERMAL EXPANSION HAZARD</p> <p><i>Fluid subjected to heat in confined spaces, including hoses, can create a rapid rise in pressure due to the thermal expansion. Over-pressurization can result in equipment rupture and serious injury.</i></p> <ul style="list-style-type: none"> • Open a valve relieves the fluid expansion during heating. • Replace hoses proactively at regular intervals based on your operation conditions.

**WARNING****PRESSURIZED ALUMINUM PARTS HAZARD**

Use of fluids that are incompatible with aluminum in pressurized equipment can cause serious chemical reaction and equipment rupture. Failure to follow this warning can result in death, serious injury, or property damage.

- *Do not use 1,1,1-trichloroethane, methylene chloride, other halogenated hydrocarbon solvents for fluids containing such solvents.*
- *Many other fluids may contain chemicals that can react with aluminum. Contact your material supplier for compatibility.*

**EQUIPMENT MISUSE HAZARD**

Misuse can cause death or serious injury.

- *This equipment is for **Professional** use only.*
- *Do not leave the work area while the equipment is energized or under pressure. Turn off all equipment when the equipment is not in use.*
- *Do not operate the unit when fatigued or under the influence of drugs or alcohol.*
- *Do not exceed the maximum working pressure or temperature rating of the lowest rated system component. See **Technical Data** in all equipment manual.*
- *Use fluids and solvents that are compatible with equipment wetted parts. See **Technical Data** in all equipment manuals. Read fluid and solvent manufacturer's warnings. For complete information about your material, request MSDS forms from distributor or retailer.*
- *Check equipment daily. Repair or replace worn or damaged parts immediately with genuine manufacturer's replacement parts only.*
- *Do not alter or modify equipment.*
- *Use equipment only for its intended purpose. Call your distributor for information.*
- *Route hoses and cables away from traffic areas, sharp edges, moving parts, and hot surfaces.*
- *Do not kink or over bend hoses or use hoses to pull equipment.*
- *Keep children and animals away from work area.*
- *Comply with all applicable safety regulations.*



WARNING



MOVING PARTS HAZARD





Moving parts can pinch or amputate fingers and other body parts.



- *Keep clear of moving parts.*
- *Do not operate equipment with protective guards or covers removed.*
- *Pressurized equipment can start without warning. Before checking, moving, or servicing equipment, follow the Pressure Relief Procedure in this manual. Disconnect power or air supply.*

BURN HAZARD

Equipment surfaces and fluid that's heated can become very hot during operation. To avoid severe burns, do not touch hot fluid or equipment. Wait until equipment/fluid has cooled completely.

2. Important Two-Component Material Information

Isocyanate Conditions	
    	<ul style="list-style-type: none"> • <i>Spraying or dispensing materials containing isocyanates creates potentially harmful mists, vapors, and atomized particulates.</i> • <i>Read material manufacturer’s warnings and material MSDS to know specific hazards and precautions related to isocyanates.</i> • <i>Prevent inhalation of isocyanate mists, vapors, and atomized particulates by providing sufficient ventilation in the work area. If sufficient ventilation is not available, a supplied-air respirator is required for everyone in the work area.</i> • <i>To prevent contact with isocyanates, appropriate personal protective equipment, including chemically impermeable gloves, boots, aprons, and goggles, is also required for everyone in the work area.</i>

Material Self-ignition	
 	<p><i>Some materials may become self-igniting if applied too thickly. Read material manufacturer’s warnings and material MSDS.</i></p>

Keep Components A and B Separate



Cross-contamination can result in cured material in fluid lines which could cause serious injury or damage equipment. To prevent cross-contamination of the equipment's wetted parts, never interchange component A (isocyanate) and component B (resin) parts.

Moisture Sensitivity of Isocyanates

Isocyanates (ISO) are catalysts used in two component foam and polyurethane coatings. ISO will react with moisture (such as humidity) to form small, hard, abrasive crystals, which become suspended in the fluid. Eventually a film will form on the surface and the ISO will begin to gel, increasing in viscosity. If used, this partially cured ISO will reduce performance and the life of all wetted parts.

The amount of film formation and rate of crystallization varies depending on the blend of ISO, the humidity, and the temperature.

To prevent exposing ISO to moisture:

- Always use a sealed container with a desiccant dryer in the vent, or a nitrogen atmosphere. Never store ISO in an open container.
- Keep the ISO lube pump reservoir (if installed) filled with DOP. The lubricant creates a barrier between the ISO and the atmosphere.
- Use moisture-proof hoses specifically designed for ISO, such as those supplied with your system.
- Never use reclaimed solvents, which may contain moisture. Always keep solvent containers loosed when not in use.
- Never use solvent on one side if it has been contaminated from the other side.
- Always lubricate threaded parts with ISO pump oil or grease when reassembling.

Changing Materials

- When changing materials, flush the equipment multiple times to ensure it is thoroughly clean.
- Always clean the fluid inlet strainers after flushing.
- Check with your material manufacturer for chemical compatibility.
- Most materials use ISO on the RED drum, and POLY on the BLUE drum.

3. Flow Charts of Raw Material

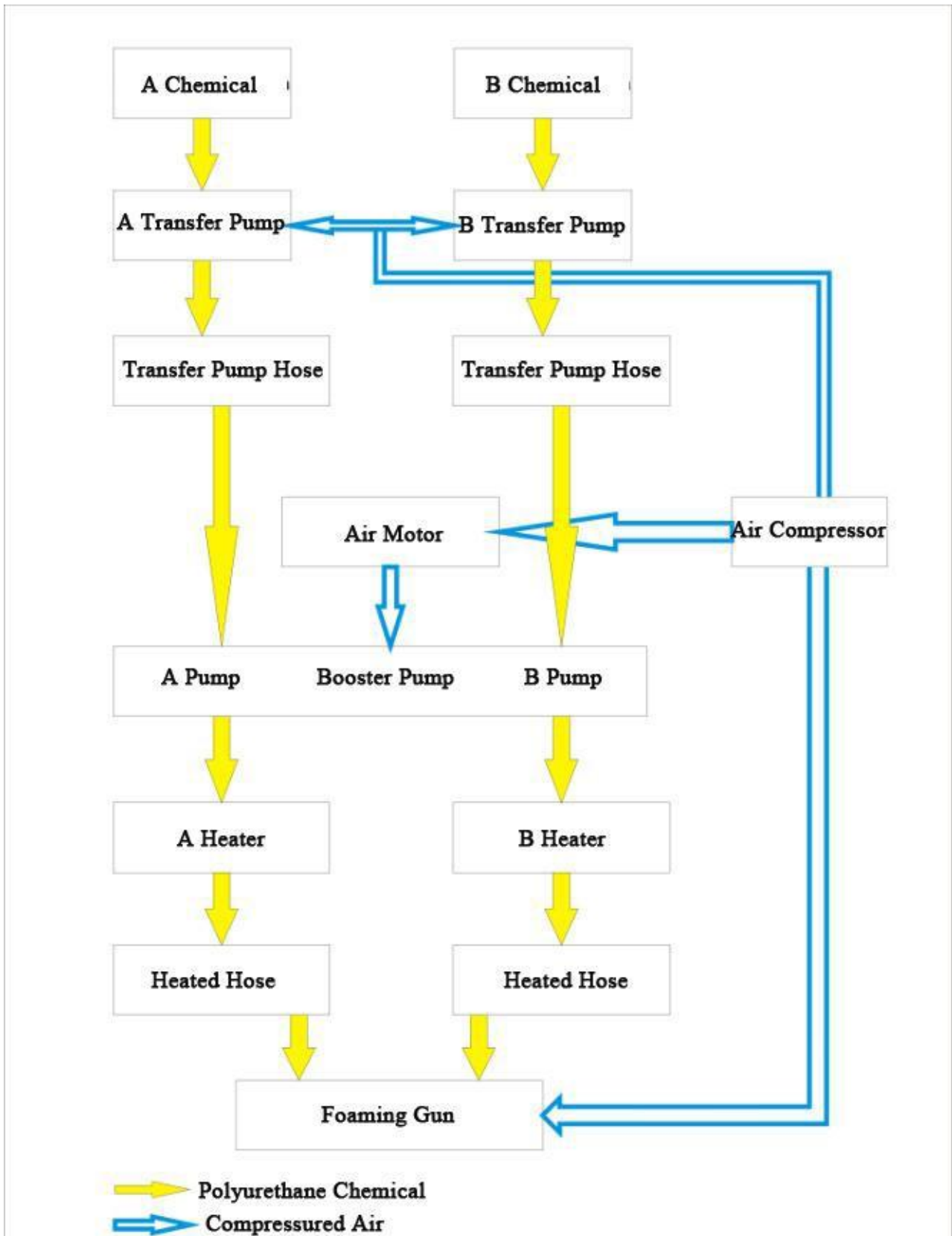

4.1 Installation of air supply system:

1. Connect main air line from air compressor to the main air inlet,
2. Connect the air line in heated hose to mainframe,
3. Connect air lines from mainframe to transfer pumps.

See figure (1) (2).

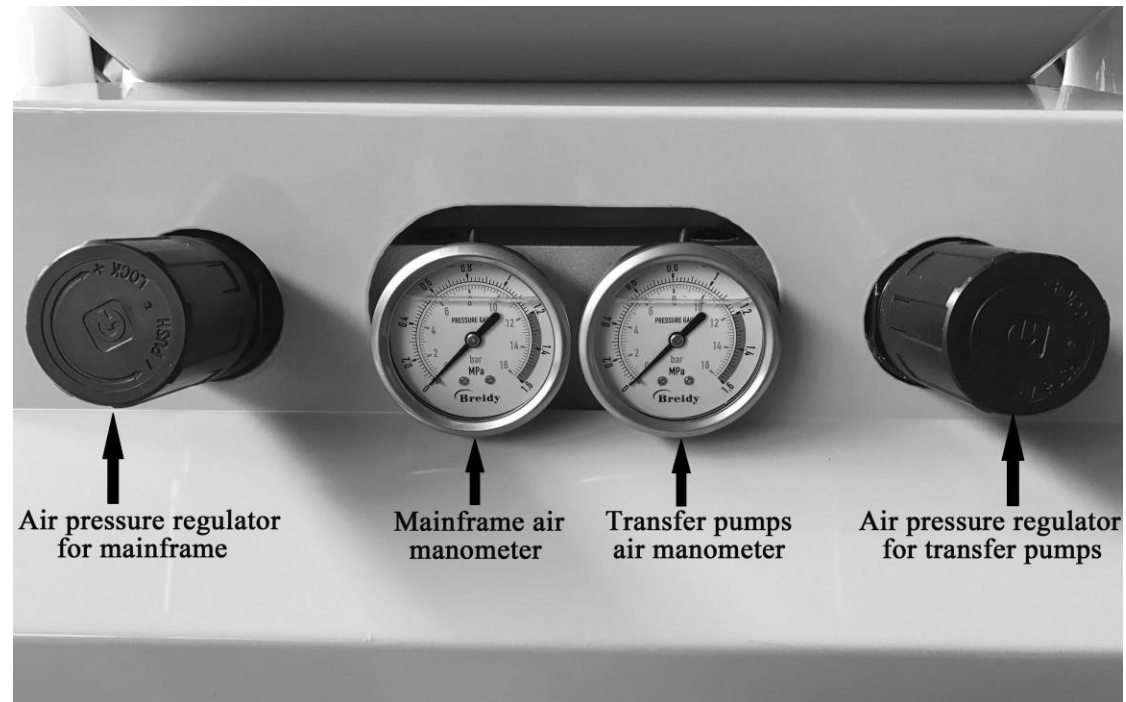

Figure (1)

Air pressure regulator for mainframe:

Used to adjust the mainframe air pressure, pull the knob to adjust the air pressure, “+” to increase the air pressure, “-” to reduce the air compressor, press the knob to lock it.

Mainframe air manometer:

Displays the mainframe air pressure, when the mainframe air regulator is adjusted, the

current air pressure is displayed.

Air pressure regulator for transfer pumps:

Used to adjust two transfer pumps air pressure, pull the knob to adjust the air pressure, “+” to increase the air pressure, “-” to reduce the air compressor, press the knob to lock it.

Transfer pumps air manometer:

Displays two transfer pumps air pressure, when the transfer pump air regulator is adjusted, the current air pressure is displayed.

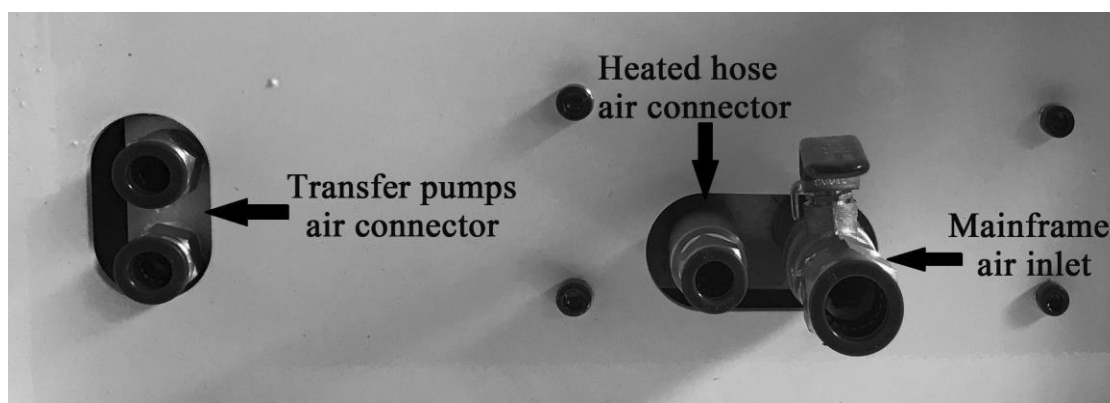

Figure (2)

Mainframe air inlet:

The total air supply inlet of the whole system, the compressed air from the air compressor enters the system through this connector.

Heated hose air connector:

This connector connects the air line in the heated hose, to provide compressed air as power to the foam gun.

Transfer pumps air connector:

Connects air lines to A and B transfer pumps separately, to provide compressed air as power to A and B transfer pumps.

4.2 Installation of raw material transfer system:

Lead the POLY and ISO from material drum to the pump entrance of the mainframe; connect hoses of chemical material and air to spray gun respectively as the following steps.

WARNING

- *Before installing the raw material lines, make sure the equipment is not electrified.*
- *Under ordinary pressure, the foaming agent will expand intensively when the temperature of raw material is more than 73 degrees Fahrenheit.*

1. Installation of transfer pump system:

Open the drum put in the material transfer pump slowly till to the bottom.

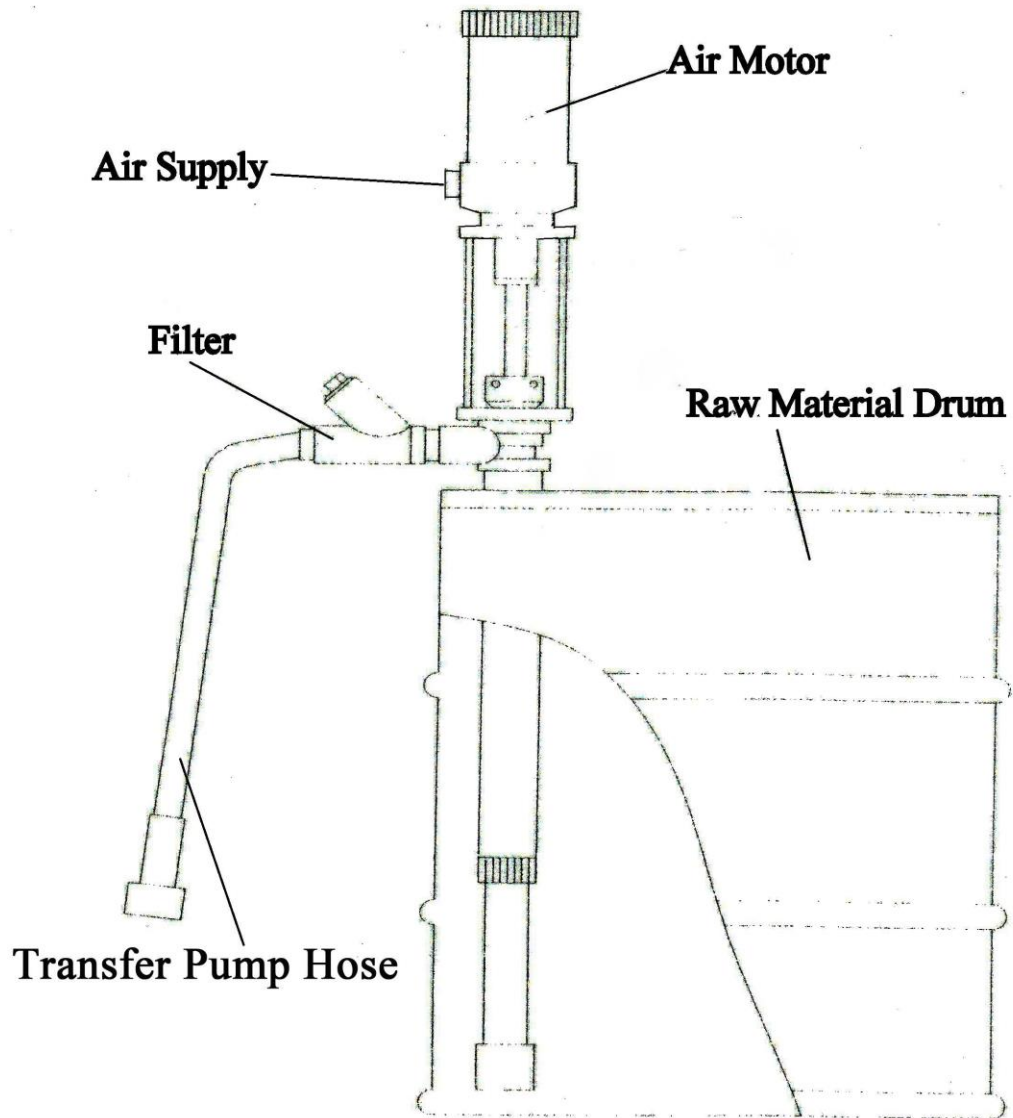

Connect the transfer pump hose and the booster pump entrance of the mainframe respectively. As figure (3)

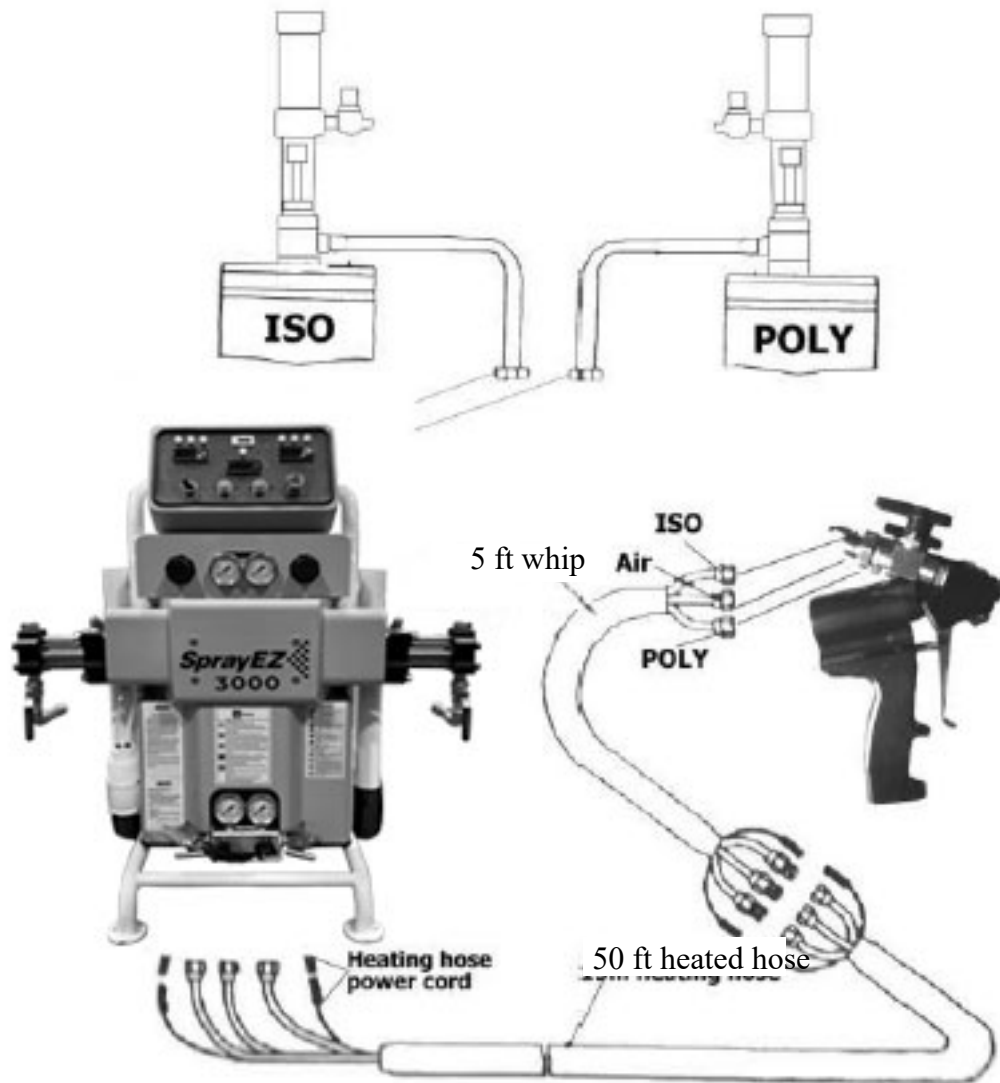

Figure (4)

4.3 Installation of heating hose

Connect the heated hose to the mainframe and spray gun respectively. See figure (4). Connect one of the heated hose power wire to the 0v tap and connect the other wire to the tap that gives you 40 amps or less on the heated hose. See Figure (5).

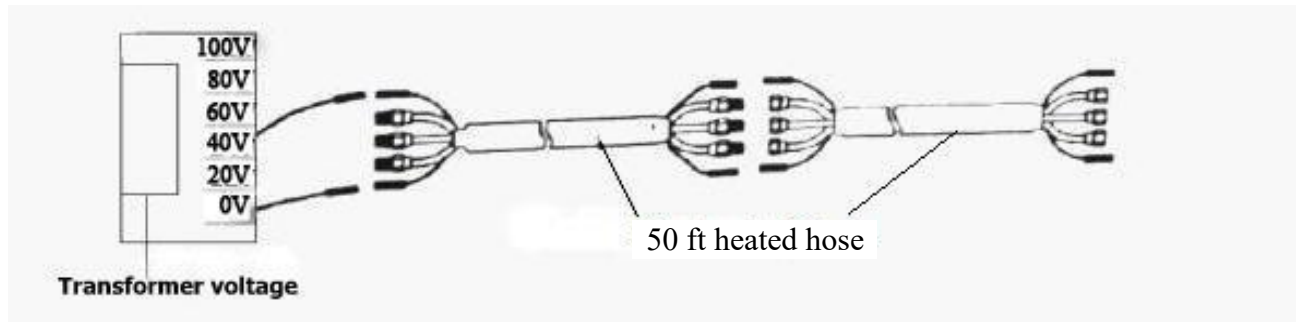

Figure (5)

4.4 The connection and requirement of power source

Connect the power line from the mainframe to single-phase 220V 50 amp power.

WARNING

- *Installing this equipment requires access to parts which may cause electric shock or other serious injury if work is not performed properly. Be sure your installation complies with all National, State and Local safety, electrical, and fire codes.*

4.5 Instrument panel: as figure (7)



Figure (7)

Emergency Stop:

Press the stop switch in an emergency situation, then the machine will stop working, but the equipment will still be electrified. Be sure to cut off the main power if you want to maintain the equipment. After finishing maintenance, turn the knob clockwise then it will reset, and the equipment recovers to working state.

Main Switch for Heater:

The heater power switch controls the A and B heater power. Press this button and the A, B temperature controller will display.

Hose Switch:

The hose switch controls the heated hose power. Press this button and the hose temperature controller will display.

Temperature Controller:

A Isocyanate temperature controller for A side heater temperature display and set, B Polyol temperature controller for B side heater temperature display and set, Hose temperature controller for heated hose temperature display and set.

How to set temperature:

1. Press “MAIN SWITCH FOR HEATER” to “ON” position,
2. Press “SET” knob on the controller three times, the LED digital Continues flashing,
3. Press ▲ or ▼ to set the temperature,
4. Press “SET” one time to finish the setting.

Counts

For recording the booster pump stroke count, press the reset button on counter back to zero.

ON/OFF Switch for Machine

This switch controls the booster pump movement. It has two positions, “WORK” and “RESET.” In the WORK” position, the air motor drives the booster pump building pressure on the system, in the “RESET” position, the air motor stops working.

4.6 Main Power Switch and Voltage Display

The main power switch (as Figure 8) is the total power switch, controls the heater power, heated hose power and all electrical parts. Please note that even with this switch in the off position, portions of the machine are still electrified. Please disconnect power supply before servicing machine.

The voltage display show the shows the voltage of the currently connected power supply.

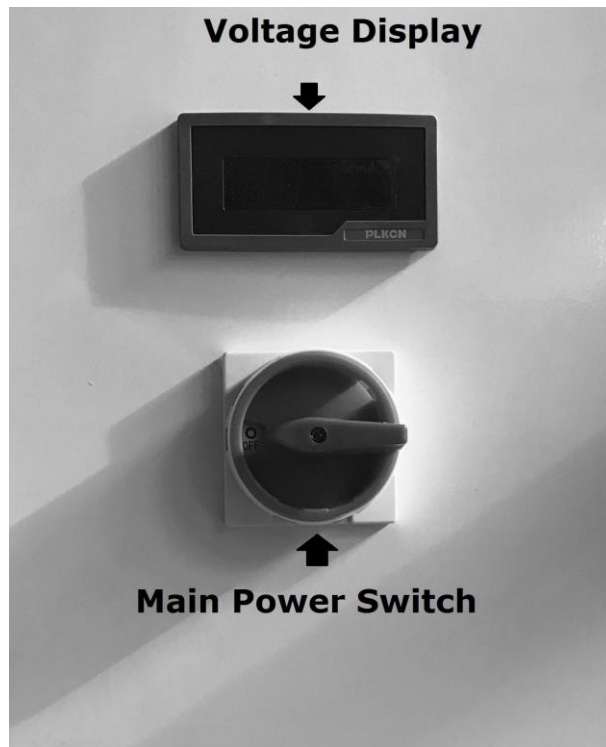

Figure (8)

4.7 Air Motor Heater Switch

In order to prevent the air motor from freezing in cold winter, the air motor has a heating band, the switch for air motor heater is in the electrical box, if do not use air motor heater, you can turn it off. See Figure (9).

The power supply of the air motor heater is AC40V, from the transformer, never disconnect the power supply of air motor heater.

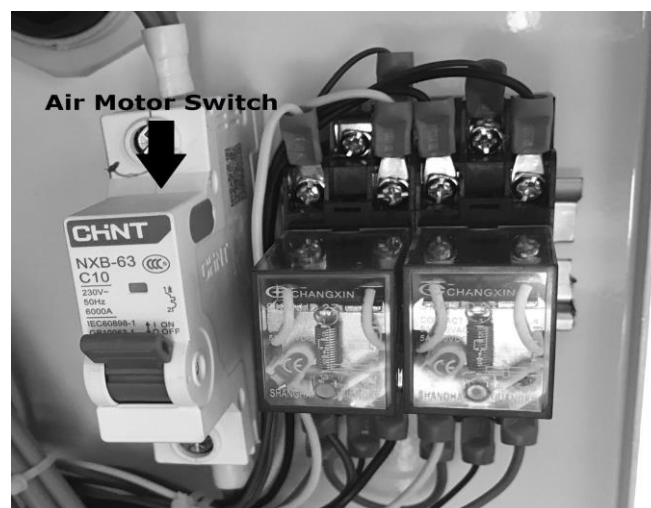

Figure (9)

5. System Operation

5.1 Check these items before operating

1. Make sure the TSL container is 4/5 full to prevent the ISO chemical in the booster pump from crystallizing. The supply line (Coarser line) should be in the cup 1/3 position, return line (Finer line) in the bottom of the cup. (Figure 10).

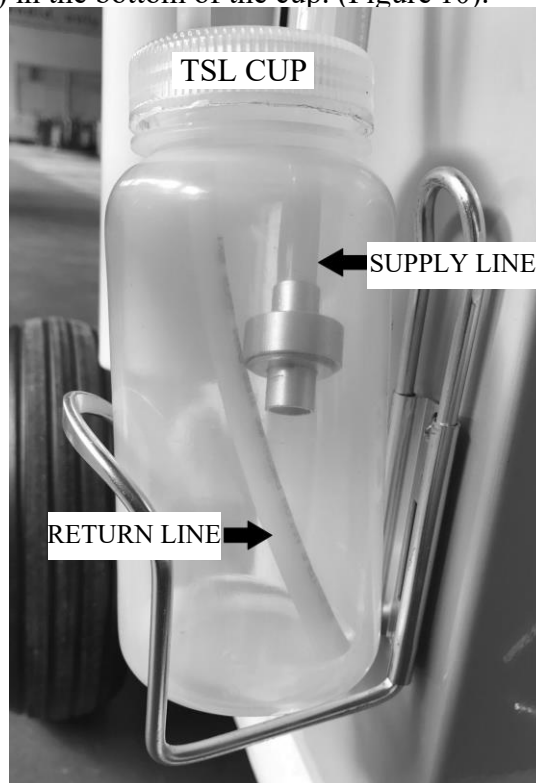

Figure (10)

2. Check that all connections are tight.
3. Check the connection of power line and make sure it is properly grounded.
4. Check that all switches on the control panel are in the OFF position.
5. Check that the air supply regulator is in the OFF position.

Don't put any parts of body in the range of spray.

Don't let the gun point to someone.

Don't look into the hole of the gun mixing chamber.

Please use proper PPE like mask, gloves, goggles and protective clothing.

5.2 Initial start (the first use of the new machine)

NOTICE

Proper system setup, startup, and shutdown procedures are critical to electrical equipment reliability. Failure to follow safety procedures will cause voltage fluctuations that can damage electrical equipment and void the warranty.

WARNING

Do not operate this machine without all covers and shrouds in place.

Before you operate the system you must make sure all fluid flow lines, air supply lines and power lines are connected and correct. The operator must fully understand every part on the control panel.

5.3 Daily shutdown steps

NOTICE

Put the reset/work transfer switch to the reset every time you shutdown, this will keep the pump shaft from being exposed to air

1. Press Main Switch for Heater button, shut down the heated system,
2. Press Hose Switch, shut down the heated hose system,
3. Turn ON/OFF Switch for Machine to “Reset” position,
4. Close two valves on the gun block
5. Pull the gun trigger several times to clean the gun and then grease it.
6. Close the air supply of the whole system,
7. Disconnect the power cord from the whole system,
8. Clean up the site, confirm the daily shutdown steps are completed.

5.4 Daily maintenance

Check the quantity and color of the TSL in the TSL cup. Change the TSL fluid if discolored.

NOTICE

You need to change the seal element if the grease in the oil cup discolors in a short time.

NOTICE

Discharge all the air pressure and hydraulic pressure before repairing or maintaining the system.

5.5 Operation of long-term shutdown

This step is for long term shutdown of the system.

Flush the A side of system with the flush fluid and then fill the A side line with the storage fluid.

NOTICE

Isocyanate will crystallize when exposed to air, all inlet and outlets must be sealed to prevent air from entering.

6. Check for Fluid Flow System and Equipment

Problems

You must know the following items as a qualified operator:

1. What does the normal raw material look like?
2. How to operate the equipment.
3. How to circulate the raw material in the machine.

6.1 Make sure pressure on both A and B hoses are equal before spraying. If one is higher pressure, bleed off some pressure on the higher side until they are equal.

1. If the raw material pressure is too low check the following:

- (1) Is there any raw material in the drum?
- (2) What's the temperature of raw material?
 - A. If temperature is above 85 degrees on the closed cell poly, it may foam up in the drum.
 - B. Low temperature of the material will cause viscosity to increase, preheat material before spraying.

Circuit Diagram (Single-phase 220V)

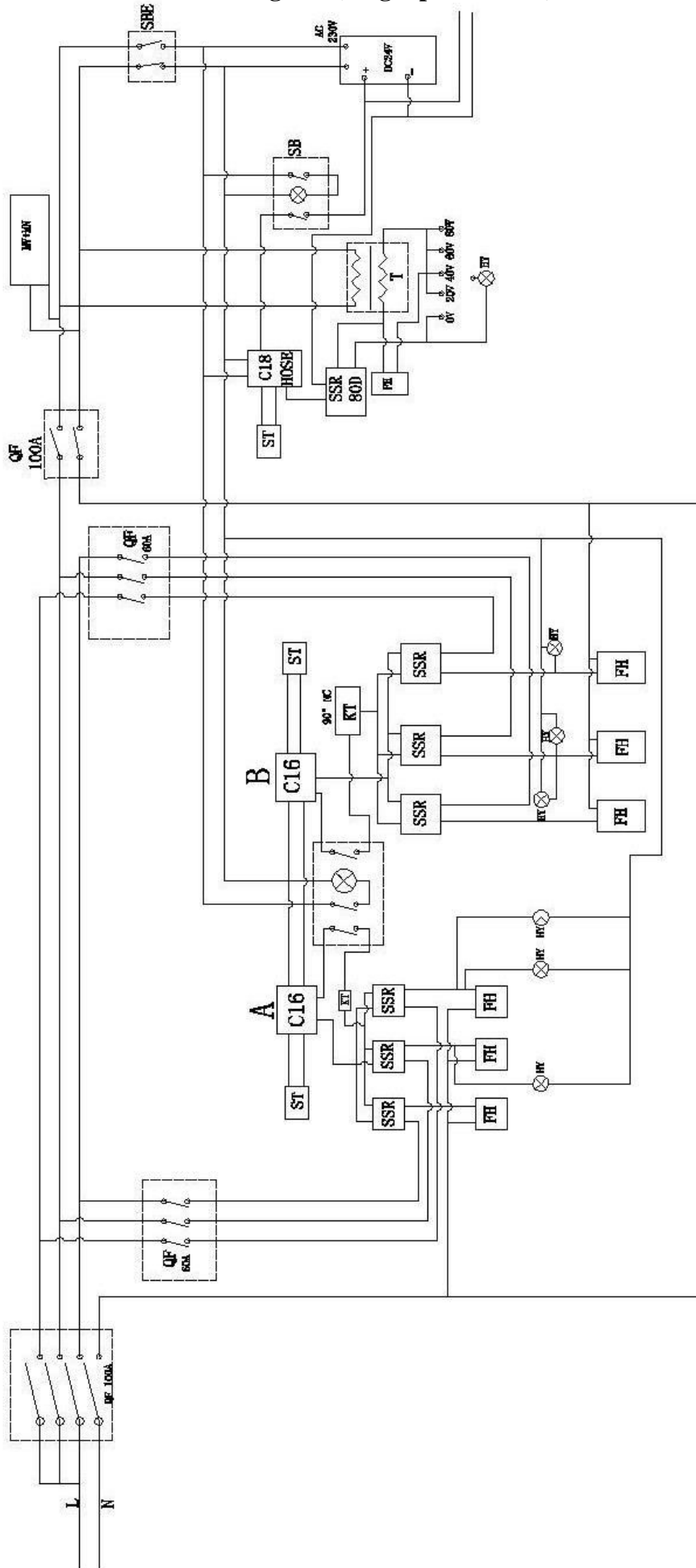

Booster Pump Decomposition Diagram

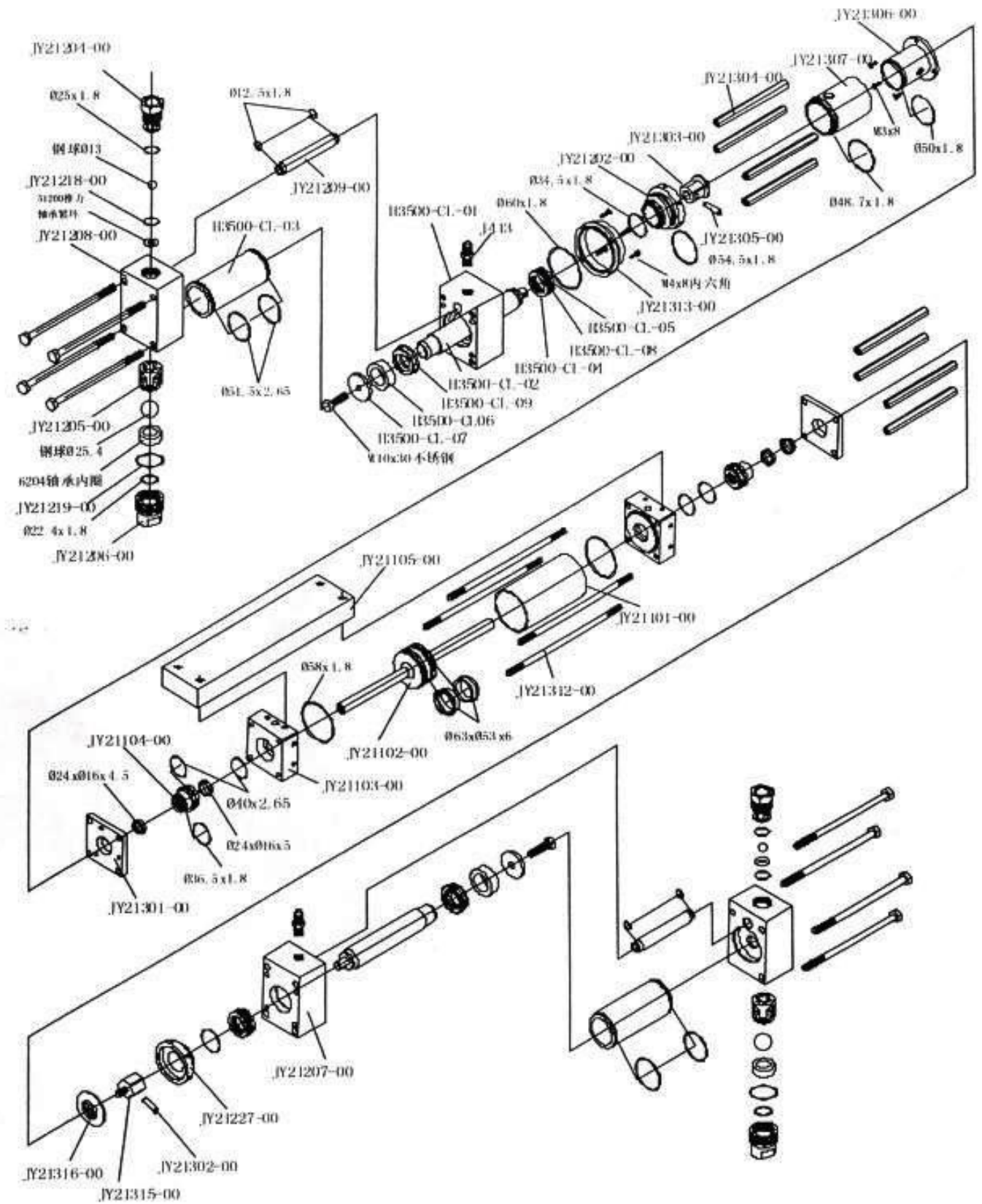



SPRAY EQUIPMENT AND COATINGS

EQUIPMENT WARRANTY

SPRAY EQUIPMENT AND COATINGS, INC. WARRANTS ALL EQUIPMENT BEARING ITS NAME TO BE FREE FROM DEFECTS IN MATERIAL AND WORKMANSHIP ON THE DATE OF SALE TO THE ORIGINAL PURCHASER FOR USE. WITH THE EXCEPTION OF ANY SPECIAL, EXTENDED, OR LIMITED WARRANTY PUBLISHED BY SPRAY EQUIPMENT AND COATINGS, INC., SPRAY EQUIPMENT AND COATINGS, INC. WILL, FOR A PERIOD OF TWELVE MONTHS FROM THE DATE OF SALE, REPAIR OR REPLACE ANY PART OF THE EQUIPMENT DETERMINED BY SPRAY EQUIPMENT AND COATINGS, INC. TO BE DEFECTIVE. THIS WARRANTY APPLIES ONLY WHEN THE EQUIPMENT IS INSTALLED, OPERATED AND MAINTAINED IN ACCORDANCE WITH SPRAY EQUIPMENT AND COATINGS, INC.'S RECOMMENDATIONS. THIS WARRANTY DOES NOT COVER, AND SPRAY EQUIPMENT AND COATINGS, INC. SHALL NOT BE LIABLE FOR GENERAL WEAR AND TEAR, OR ANY MALFUNCTION, DAMAGE OR WEAR CAUSED BY FAULTY INSTALLATION, MISAPPLICATION, ABRASION, CORROSION, INADEQUATE OR IMPROPER MAINTENANCE, NEGLIGENCE, ACCIDENT, TAMPERING, OR SUBSTITUTION OF NON-SPRAY EQUIPMENT AND COATINGS, INC. COMPONENT PARTS. NOR SHALL SPRAY EQUIPMENT AND COATINGS, INC. BE LIABLE FOR MALFUNCTION, DAMAGE OR WEAR CAUSED BY THE INCOMPATIBILITY OF SPRAY EQUIPMENT AND COATINGS, INC. EQUIPMENT WITH STRUCTURES, ACCESSORIES, EQUIPMENT OR MATERIALS NOT SUPPLIED BY SPRAY EQUIPMENT AND COATINGS, INC., OR THE IMPROPER DESIGN, MANUFACTURE, INSTALLATION, OPERATION OR MAINTENANCE OF STRUCTURES, ACCESSORIES, EQUIPMENT OR MATERIALS NOT SUPPLIED BY SPRAY EQUIPMENT AND COATINGS, INC.

THIS WARRANTY IS CONDITIONED UPON THE PREPAID RETURN OF THE EQUIPMENT CLAIMED TO BE DEFECTIVE TO AN AUTHORIZED SPRAY EQUIPMENT AND COATINGS, INC. DISTRIBUTOR FOR VERIFICATION OF THE CLAIMED DEFECT. IF THE CLAIMED DEFECT IS VERIFIED, SPRAY EQUIPMENT AND COATINGS, INC. WILL REPAIR OR REPLACE FREE OF CHARGE ANY DEFECTIVE PARTS. THE EQUIPMENT WILL BE RETURNED TO THE ORIGINAL PURCHASER TRANSPORTATION PREPAID. IF INSPECTION OF THE EQUIPMENT DOES NOT DISCLOSE ANY DEFECT IN MATERIAL OR WORKMANSHIP, REPAIRS WILL BE MADE AT A REASONABLE CHARGE, WHICH CHARGES MAY INCLUDE THE COSTS OF PARTS, LABOR, AND TRANSPORTATION.

THIS WARRANTY IS EXCLUSIVE, AND IS IN LIEU OF ANY OTHER WARRANTIES, EXPRESS OR IMPLIED, INCLUDING BUT NOT LIMITED TO WARRANTY OF MERCHANTABILITY OR WARRANTY OF FITNESS FOR A PARTICULAR PURPOSE.



SPRAY EQUIPMENT AND COATINGS, INC. SOLE OBLIGATION AND BUYER'S SOLE REMEDY FOR ANY BREACH OF WARRANTY SHALL BE AS SET FORTH ABOVE. THE BUYER AGREES THAT NO OTHER REMEDY (INCLUDING, BUT NOT LIMITED TO, INCIDENTAL OR CONSEQUENTIAL DAMAGES FOR LOST PROFITS, LOST SALES, INJURY TO PERSON OR PROPERTY, OR ANY OTHER INCIDENTAL OR CONSEQUENTIAL LOSS) SHALL BE AVAILABLE.

SPRAY EQUIPMENT AND COATINGS, INC. MAKES NO WARRANTY, AND DISCLAIMS ALL IMPLIED WARRANTIES OF MERCHANTABILITY AND FITNESS FOR A PARTICULAR PURPOSE, IN CONNECTION WITH ACCESSORIES, EQUIPMENT, MATERIALS OR COMPONENTS SOLD BUT NOT MANUFACTURED BY SPRAY EQUIPMENT AND COATINGS, INC. THESE ITEMS SOLD, BUT NOT MANUFACTURED BY SPRAY EQUIPMENT AND COATINGS, INC. ARE SUBJECT TO THE WARRANTY, IF ANY, OF THEIR MANUFACTURER.

IN NO EVENT WILL SPRAY EQUIPMENT AND COATINGS, INC. BE LIABLE FOR INDIRECT, INCIDENTAL, SPECIAL OR CONSEQUENTIAL DAMAGES RESULTING FROM SPRAY EQUIPMENT AND COATINGS, INC. SUPPLYING EQUIPMENT HEREUNDER, OR THE FURNISHING, PERFORMANCE, OR USE OF ANY PRODUCTS OR OTHER GOODS SOLD HERETO, WHETHER DUE TO A BREACH OF CONTRACT, BREACH OF WARRANTY, THE NEGLIGENCE OF SPRAY EQUIPMENT AND COATINGS, INC. OR OTHERWISE.

NOTE

.....

.....

.....

.....

.....

.....

.....

.....

.....

.....

.....

.....

.....

.....

.....

.....

.....

.....

.....

.....

.....

.....

.....

.....

.....

.....